

A matter of experience.

N&W has been developing and producing automatic beverage dispensers for the Out-of-Home and Catering sectors for many years and supplies over 100 countries. This market leadership has been achieved and maintained by investing heavily in research and development and is the result of many years of technical and manufacturing experience, combined with a passion for innovation and design.

Necta HoReCa products are developed and produced using processes approved to two internationally recognised standards, one for quality - UNI EN ISO 9001:2008 - and one for the environment - UNI EN ISO 14001:2004. N&W is committed to providing the market with first-class high quality products and the quality certification of all its plants underlines this significant commitment. With regard to the environment, N&W has always paid great attention to the environmental impact of its products and processes and continuously strives to keep this to a minimum.

A further important certification achieved by N&W is supplied by IMQ, Istituto Italiano del Marchio di Qualità (Italian Quality Trademark Institute). This certification assures all Necta products meet the home appliance safety standards as well as the safety standards for commercial dispensers.

**GREENER
BY NATURE**



SA TOMA AG

SA TOMA AG
Gummertliweg 7
4702 Oensingen
T. 062 388 20 50
F. 062 388 20 55
info@satoma.ch
www.satoma.ch



N&W Global Vending reserves the right to alter specifications without notice.

L252U9

NECTA

**GREENER
BY NATURE**

K O R O



O

R

E



NECTA

Koro, a touch of class.

To truly enjoy a fresh cup of coffee, we find it helps if you close your eyes, inhale, take in the aroma and then take pleasure in the taste of a great cup of coffee. It all forms part of the ritual of drinking coffee. In everyday life, at work or during free time, we always find the right moment to indulge in this great little pleasure.

Koro comes from the technology and experience of Necta. With soft clean lines, Koro offers typically elegant classic Italian design, aesthetically pleasing, it provides excellent value for money whilst benefiting from being technically superior. Koro is extraordinarily compact and reliable, due to the use of the highest quality components, normally used in machines that support much heavier workloads.

Thanks to its characteristics, Koro is ideal for environments such as offices, meeting rooms, stores, professional studios, small cafés and restaurants, and can be managed in a variety of ways.



Superior technology to satisfy every need

If it's style and sophistication you're looking for, Koro has the answer.



Thanks to the different technologies for preparing drinks, the machine represents the ideal solution for hot drinks services of a superior quality, with a menu to satisfy every taste.



Espresso

Thanks to the patented coffee group, the volumetric doser and the perfect extraction according to the parameters of the best Italian espresso, Koro offers excellent coffee and a variety of other hot beverages, including a wonderful frothy cappuccino using fresh milk in order to get the perfect foam thanks to the new cappuccinatore.



Simple and stylish

Style and simplicity are synonymous with Koro, and its ease of use is down to the simple display and conveniently situated buttons, directing the user in their choice of preferred beverage.



Koro has a wide drinks menu and can offer up to eight different drinks, and through there versatility they are at home in any situation.



Koro is also small in size and light, making it easy to position into location and move around.

Easy maintenance and cleaning

The cleaning and maintenance system in Koro is simplicity itself. The optimisation of the mixer's parts (only three components), the suction of dust through a small built-in drawer, and the dust conveyor make cleaning operations quick and simple. Mixers are easy to remove by using the green coloured release system.

Accessories

In order to suit every client's requirements, a complementary range of accessories is available including:

- Super-equipped base cabinet with solid and liquid waste containers plus cups/sugar/stirrers holders
- Payment system module
- Cup holder module
- Cup warmer
- Fridge
- 20 litre water self feeding tank
- Water filter kit

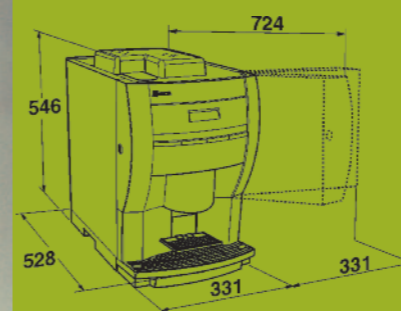

Dimensions in mm



**GREENER
BY NATURE**

- We were first in the business to achieve ISO 14001
- We lead the way with lean, green production processes
- Avex 2007 Awards Best Sustainability award
- Vending Paris 2008 Awards Best Sustainable Development & the Environment
- We apply Life Cycle Product Design
- We adhere to a stringent Environmental Management System
- We adopt product Life Cycle Assessment
- We're proud to be a member of the EMP committee

KORO Espresso with cappuccinatore

Drinks delivered

Espresso
Long Black
White Coffee
Caffè Latte
Cappuccino
Caffè Mocha
Chocolate
Hot water

Ingredients capacity

Coffee beans 0.75 kg
Chocolate 0.65 kg

Weight

28 kg

Hourly output

50 cappuccinos

Power

2850 W

Boiler

600 cc Espresso
500 cc Steam



KORO Espresso

Drinks delivered

Espresso
Long coffee
White coffee
Cappuccino
Caffè Latte
Cancel deca
Hot milk
Hot water

Ingredients capacity

Coffee beans 0.75 kg
Whitener 0.65 kg

Weight

27 kg

Hourly output

40 espressos

Power

1500 W

Boiler

300 cc

